



■ **EASE OF INSTALLATION AND SERVICEABILITY**

- Compact Design to Save Space
- Wi-Fi Technology for Remote Monitoring and Management
- Simple Gas Conversion

■ **OPTIONAL ACCESSORIES**

Condensate Neutralizer, ScaleCutter, Drain Down Kit, Additional Controllers, Recess Box, Pipe Cover, Recirculation Pump, DPS/MIS Switch, EZ Connect Cables, Control-R™ WI-FI Module, Wireless Accessories, and many more.

Visit rinnai.us for a complete list of accessories.

SUPER-HIGH-EFFICIENCY (CONDENSING) TANKLESS WATER HEATER

Installation Type	External (Outdoor) Residential Applications. Manufactured (Mobile) Home Certified	
Model Numbers	RU199e (REU-N3237W-US) RU180e (REU-N2934W-US) RU160e (REU-N2530W-US) RU130e (REU-N2024W-US)	
Approved Gas Types	Natural and Propane	
Uniform Energy Factor (UEF)	0.92	
Energy Factor (EF) (Canada)	RU199e, RU180e, RU160e:	0.96
	RU130e:	0.95
High Altitude Approved	Up to 10,200 Ft (3,109 M)	
Water Flow Control	Water Flow Sensor, Electronic Water Control and Bypass Control	
Controller	Standard: Integrated Controller Optional: MC-195T-US, MC-100V-1US, BC-100V-1US, MCC-91-2US	
Certifications	AHRI, ANSI Z21.10.3, CSA 4.3, and Energy Star®	

Warranty

- Heat Exchanger: 15 years or 12,000 operation hours, whichever occurs first
- All Other Parts and Components: 5 Years
- Reasonable Labor: 1 Year

Safety Devices

Flame Failure - Flame Rod, Boiling Protection, Combustion Fan RPM Check, Over Current - Glass Fuse, Remaining Flame (OHS) and Automatic Frost Protection

Included with Purchase

- Tankless Water Heater
- Pressure Relief Valve and Adapter
- Isolation Valve Kit
- Integrated Controller

Additional Features

- Mobile Home Certified
- Complies with South Coast Air Quality Management District 14 ng/J or 20 ppm NOx Emission Levels
- Ultra Low NOx
- Tankless Rack System™ Compatible
- 1/2 in. (13 mm) Gas Line Compatible



CERTIFIED TO ANSI Z21.10.3 — CSA 4.3

SENSEI™ TECHNICAL SPECIFICATIONS

SPECIFICATION		RU199e	RU180e	RU160e	RU130e
Dimensions - w, h, d		18.5 in. x 26.4 in. x 11.4 in. (470 mm x 670 mm x 290 mm)			
Minimum Gas Consumption Btu/h		15,000			
Maximum Gas Consumption Btu/h		199,000	180,000	160,000	130,000
Flow Rate ¹ (Min - Max)		0.26 - 9.8 GPM (1.0 - 37 L/min)	0.26 - 9.0 GPM (1.0 - 34 L/min)	0.26 - 8.0 GPM (1.0 - 30 L/min)	0.26 - 6.6 GPM (1.0 - 24 L/min)
Max Flow Rate with Parameter Adjustment		11 GPM (42 L/min)	10 GPM (38 L/min)	9 GPM (34 L/min)	7 GPM (26 L/min)
Weight		64 lb (29 kg)	64 lb (29 kg)	62 lb (28 kg)	62 lb (28 kg)
Sound Level		53 dB	52 dB	52 dB	52 dB
Electrical	Normal	81 W	62 W	49 W	36 W
	Standby	1.3 W			
	Freeze Protection	152 W			
	Max Current	4 Amps			
	Fuse	10 Amps			
Temperature		<ul style="list-style-type: none"> Minimum: 98° F (37° C) Default Maximum: 120° F (49° C) Default 140° F (60° C) With Parameter Adjustment 			
By-Pass Flow Control		Electronic			
Gas Supply Pressure ²		<ul style="list-style-type: none"> Natural: 3.5 in. w.c. - 10.5 in. w.c. Propane: 8.0 in. w.c. - 13.5 in. w.c. 			
Ignition System		Direct Electronic Ignition			
Electronic Connections		<ul style="list-style-type: none"> Appliance: AC 120 Volts, 60Hz. Temperature Controller: DC 12 Volts (Digital) 			
Water Supply Pressure		<ul style="list-style-type: none"> Minimum: 50 PSI (Recommended 60-80 PSI for max performance) Maximum: 150 PSI 			
Controller Cable		Non-Polarized Two Core Cable (Minimum 22 AWG)			
Service Connections		<ul style="list-style-type: none"> Gas Supply: 3/4 in. (19 mm) NPT Cold Water Inlet: 3/4 in. (19 mm) NPT Hot Water Outlet: 3/4 in. (19 mm) NPT Condensate Drain: 1/2 in. (13 mm) NPT 			
Clearances		<ul style="list-style-type: none"> Top: 2 in. (51 mm)* Bottom/Ground: 12 in. (305 mm) Front: 0 in.** Back: 0 in. Sides: 2 in. (51 mm)*** Front Exhaust: 24 in. (610 mm) 			

* 0 in. from vent components
 ** Clearance for servicing is 24 in. (610 mm) in front of water heater
 *** Add 0.25 in. (6.35 mm) for recess box

¹ Minimum flow may vary slightly depending on the temperature setting and the inlet water temperature.
² Minimum activation flow is 0.4 GPM (1.5 L/min).
 The maximum gas supply pressure must not exceed the value specified by the manufacturer.

SENSEI™ WATER FLOW CURVE

Flow curves apply only to incoming water temperatures of 70° F (21° C) or less.
 For incoming water temperatures greater than 70° F (21° C), please contact Rinnai.

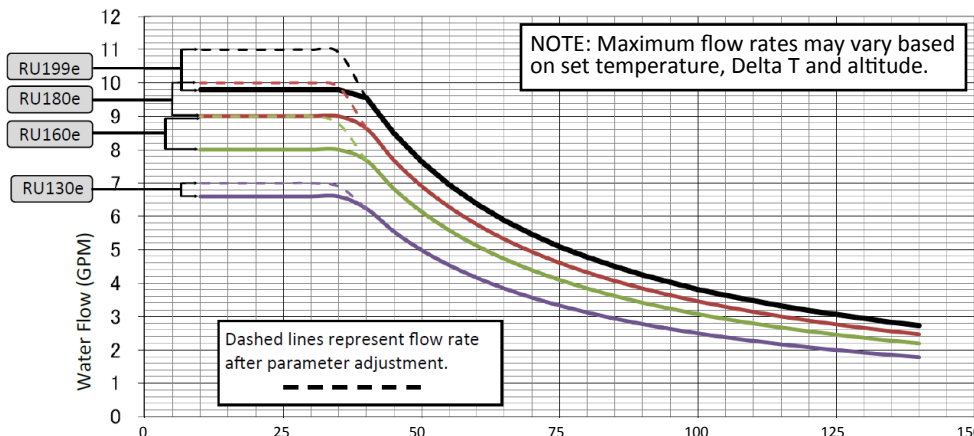

SENSEI™ DIMENSIONS

in. (mm)

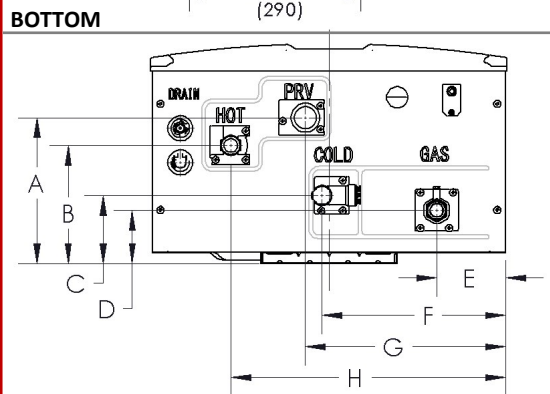
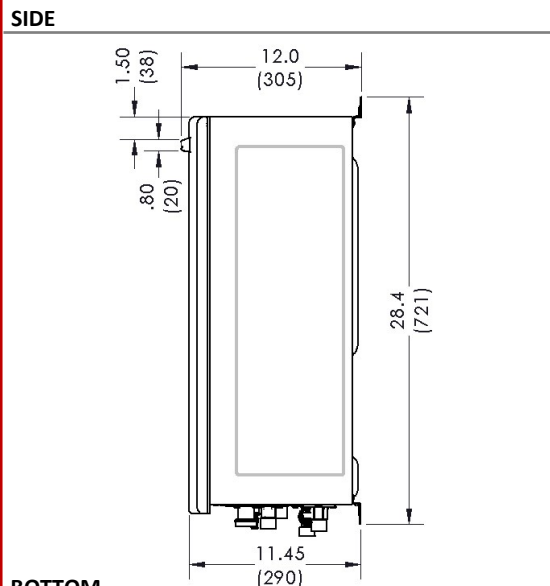
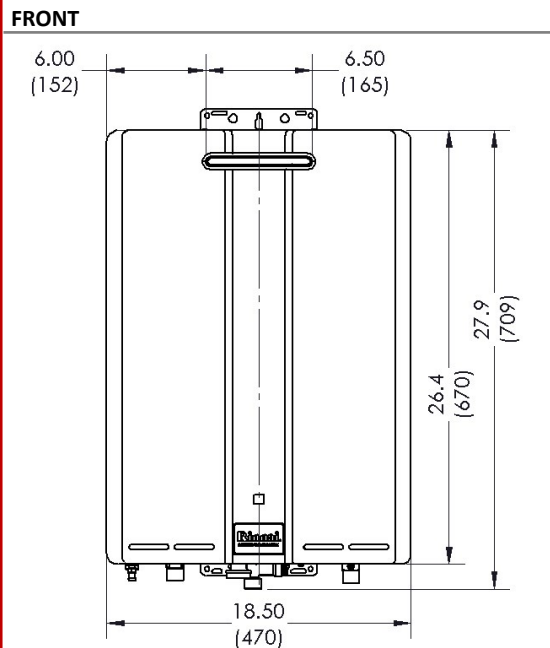

Connection	in.	mm
COLD	F	9.54 242
	C	3.56 90
HOT	H	14.27 362
	B	6.16 156
GAS	E	3.57 91
	D	2.78 71
PRV	G	10.39 264
	A	7.60 193